

NOTES:-

1. Pitch of the roof (maximum 25°, minimum 18°)
2. All welding to be 6mm thickness.
3. All gusset plate to be 10mm thickness.
4. All double angle members of trusses should be separated by welding 10mm thick 75mm long separators in 600mm c/c maximum.
5. All steel work in roof should be of grade 43 steel with yield strength - 275n/mm<sup>2</sup> ultimate tensile stress - 430 n/mm<sup>2</sup>
6. After fabrication & fixing of roof trusses, they should have been thoroughly applied with two coats of zinc phosphate paint.
7. Angle iron purlin to be 50x50x6mm thick
8. Maximum Truss Spacing 10'-0"
9. Purlin Cleat to be 75 x 75 x 6mm thick and 12" long
10. For Estimation Timber frame work should be added.
11. For 13 1/2" x 13 1/2" columns, Truss Should Be Placed on 300mm High 1:2:4 concrete Pad.

NAME OF THE PROJECT

LAYOUT & DETAILS OF STEEL ROOF TRUSS  
SPAN 6000mm(20'-0")  
(TYPE PLAN)

DRAWING TITLE

STEEL ROOF TRUSS FOR CALICUT TILE ROOFING 6000mm(20'-0")  
BSR NO: Y10 & Y25

CONNECTED DRAWING NOS

CONSULTANCY DIVISION  
ENGINEERING ORGANIZATION  
WESTERN PROVINCIAL COUNCIL  
NO: 204  
DENZIL KOBBEKADUWA MAWATHA  
BATTARAMULLA

DESIGNED BY NAME :- L. D. GALABADA  
SIGNATURE

CAD BY : NAVEEN

CHECKED BY

CHIEF ENGINEER (DESIGNS)

DIRECTOR (ENGINEERING)

SCALE -

DATE - 11/10/2021

DRG. NO  
ST/TYPE PLAN/ROOF TRUSS/2020/DETAIL-01

SHEET NO. 01

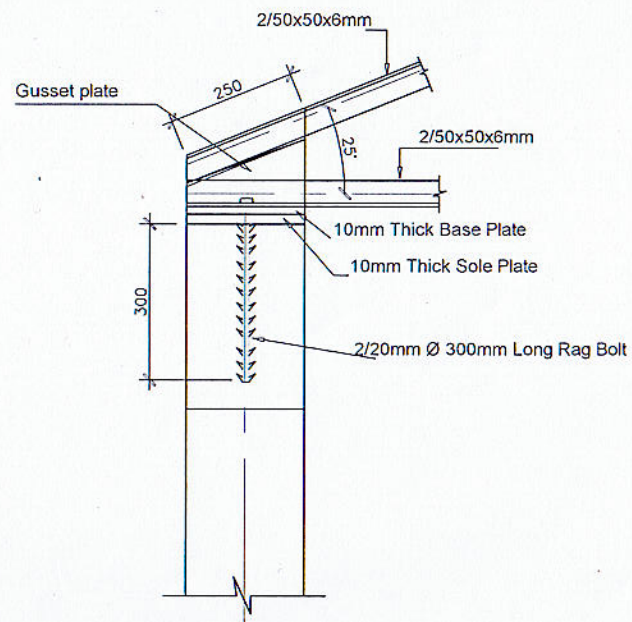

FIXED END OF TRUSS

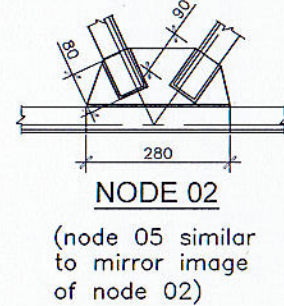

NODE 02

(node 05 similar to mirror image of node 02)

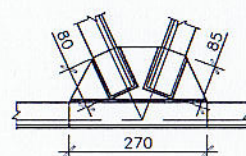

NODE 03

(node 04 similar to mirror image of node 03)

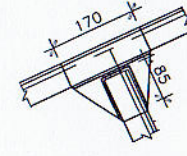

NODE 11

(node 07 similar to mirror image of node 11)

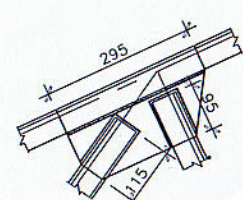

NODE 10

(node 08 similar to mirror image of node 10)

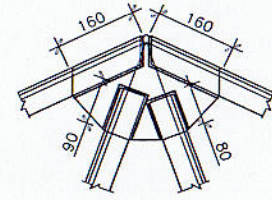

NODE 09

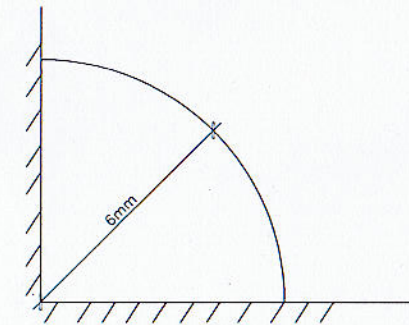

TYPICAL WELD DETAIL

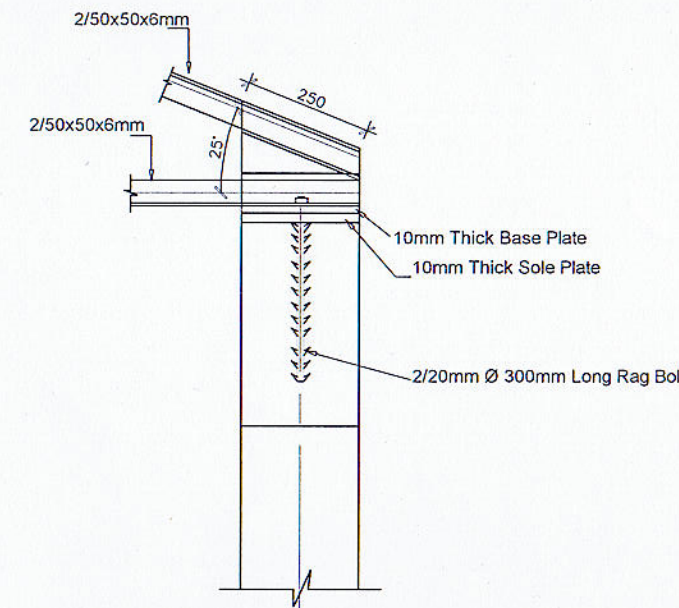

FREE END OF TRUSS

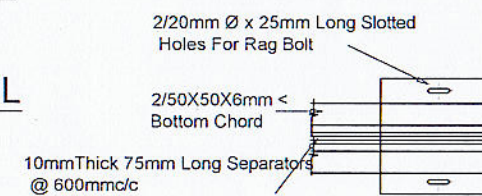

FREE END OF TRUSS (PLAN)

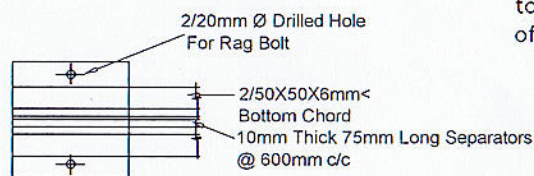

FIXED END OF TRUSS (PLAN)

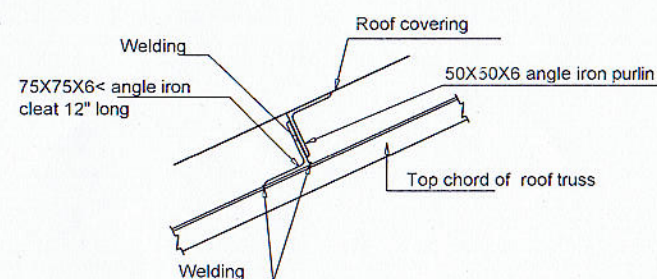

FIXING DETAIL OF PURLIN TO ROOF TRUSS