

LAMP POST
(V - 225)

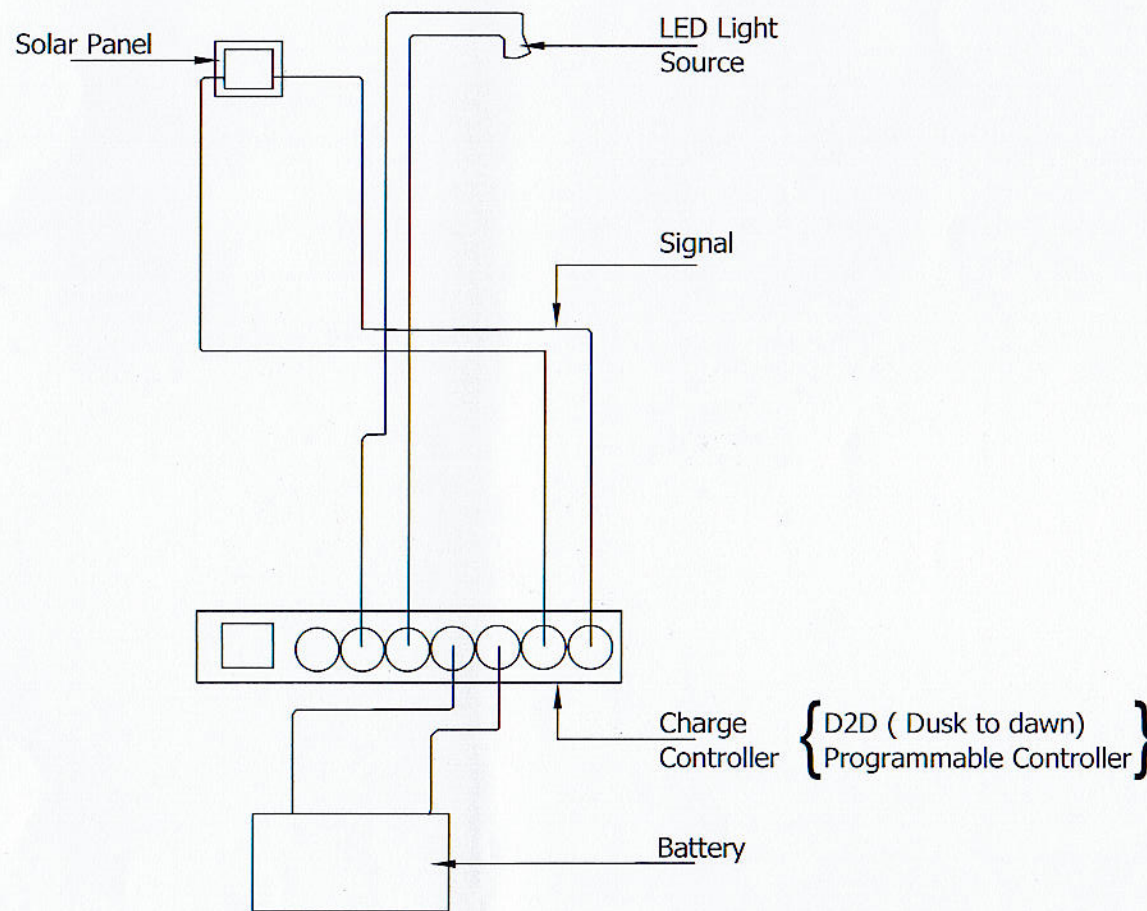

CIRCUIT DIAGRAM

Description	Make	ENAA	ENBB	Warranty
Solar Module	Enricher - China	100Wp	100Wp	25 Years
Charger Controller	EP SOLAR - China	10AMP	10AMP	2 Years
Battery	Epic / Lucas	100Ah	100Ah	2 Years
Lamp	TRITECH - China	20W	100W x 2	2 Years
Lamp Post	GI	2.5 inch	2.5 inch	10 Years

REV. NO.	DESCRIPTION	DATE	SIGNATURE
NAME OF THE PROJECT :			
PROPOSED DETAIL DRAWINGS			
DRAWING TITLE :			
DETAIL OF DOUBLE ARM SOLAR STREET LAMP			
CONNECTED DRAWING NOS.			
CONSULTANCY DIVISION ENGINEERING ORGANIZATION. WESTERN PROVINCE PROVINCIAL COUNCIL 204, DENCIL KOBBEKADUWA MAWTHA BATTARAMULLA			
DESIGNED BY	NAME	SIGNATURE	
	S.A.D.A.P. SAMARAWERA		
CAD BY :	CHECKED BY :		
UDARI			
ELECTRICAL ENGINEER	DIRECTOR (ENGINEERING)		
SCALE : 2 FEET TO AN INCH	DATE : 2020.07.10		
DRG.NO. : ELEC/ST/02	SHEET NO. : 01		